

Introducing Cyber Imaging Corporation Intelligent Thermal Technology

An improved thermal print-head and print control system

INTRODUCTION

Cyber Imaging takes the guess work out of thermal printing by introducing a vastly improved, affordable printhead system. This new Intelligent Thermal Technology thermal print-head system offers accurate high-speed temperature control without producing extra heat. Its patented feedback circuitry detects temperature in real time and is able to keep a precise temperature level regardless of outside factors.

Even with a fast through-put rate, the Intelligent Thermal Technology printhead is energy efficient. It can handle full bleed and edge-to-edge printing without over-heating the un-applied elements.

Intelligent Thermal Technology versus Conventional Technology

IMPROVED, ACCURATE CONTROL

- Intelligent Thermal Technology's Right-**on**-the-Point accuracy *measures* the heating element's temperature. Conventional technology only *guesses* the heating element's temperature.
- Intelligent Thermal Technology's temperature remains constant and will not over heat. Conventional technology's so called "smart" printhead runs in intervals and needs time to cool down between heating cycles.
- Intelligent Thermal Technology offers high linearity because the resistance of each heating element is lowered when the temperature rises. Conventional technology's elements have a fixed resistance regardless of temperature.

The Intelligent Thermal Technology Advantage

- Intelligent's Right-to-the-Point accuracy insures *continuous feedback control* that sets the heating element to the *exact* required temperature point. Conventional technology provides an open-loop control that results in unwanted heat build up.
- Intelligent Thermal Technology's printhead provides a high sampling rate of 50,000 cycles per second per point. Typical conventional technology sampling rate is only half this.

AFFORDABLE

Cost Effective. Cost and miniaturization were important considerations when developing the new Intelligent Technology thermal printhead. Our components are both energy efficient and affordable. The unique linear characteristics of the heating elements minimize the number of required components while the related temperature control and monitoring circuitry result in a less energy consuming thermal printhead.

The Intelligent Thermal Technology Advantage

The true advantage of the Intelligent Thermal Technology thermal printhead system is the quality of the printed output. The better the printhead, the better the images. This new system is the result of accurate high-speed temperature control made possible by a heating element with thermistor-like characteristics. Temperature is controlled by a patented feedback control circuit, that is hard-coded on an ASIC, rather than by a less accurate open-loop control. The printhead's heating element is made from a patented alloy. This alloy possesses high linearity temperature/resistance characteristics. It accurately detects temperature in real time and keeps a precise temperature level regardless of such factors as ambient temperature or past heat cycles. Intelligent Thermal Technology's advantage over conventional technology is clearly seen in the quality of its printed output. The results are clear in such applications as grayscale printing where near-continuous photographic results can be attained. Advantages are:

- 256-level grayscale output means quality photo printing
- Accurate and consistent reproduce-ability
- A high degree of linearity (dot shape and size versus drive voltage)

BASIC HEAD STRUCTURE

The basic printhead structure is a special patented device where each heating element is a thermistor. These heating elements are vapor-coated onto the surface of a 2 mm diameter glass tube. In Figure 1 the heating elements are labeled R1—R64. These elements have an individual width of approximately 100 microns. One connection on each of the 64 heating elements is tied in common and connected to a 19-24 volt power supply via a flexible cable. The other connection, of each of the 64 elements, is individually connected to the collector of the 64 drive transistors contained in the heat drive LSI circuit chip.

FIGURE 1. Print Head Structure

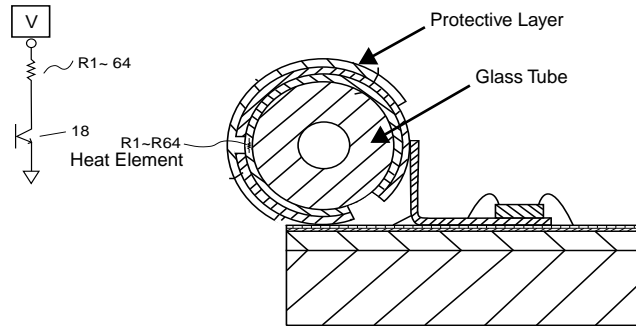

IMPROVED THERMISTOR

As stated above, the unique Intelligent Thermal Technology printhead structure is made possible by an improved thermistor (heating element). Each element is made up of a patented alloy composed of 75% Cr (Chromium) and 25% Al (Aluminum). As electrical current flows through each element, it heats up and its resistance decreases. The relationship between temperature and resistance for an ordinary thermistor is non-linear. Contrary to this, the relationship between temperature and resistance in the new thermistor is linear. Figure 2 illustrates this thermistor's highly linear, negative relationship between temperature and resistance. Successive exposure to high temperature does not affect the linear characteristics of the element and enables precise temperature control.

FIGURE 2. Thermistor Characteristics

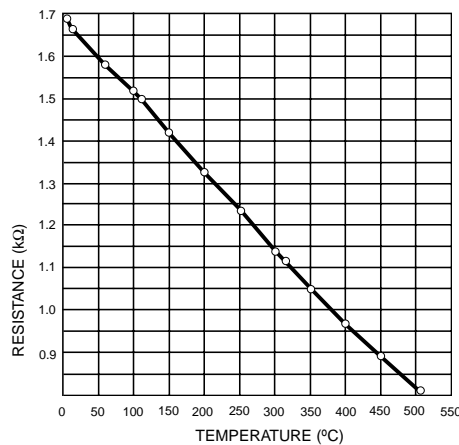

TEMPERATURE CONTROL PROCESS

Figure 3 shows the basic workings of the Intelligent Thermal Technology's printhead temperature control circuit and how it affects print density. At the top of the drawing, resistance R (104) is the heating element. Resistance r is used to measure the current flowing through R, and the transistor connected to this makes the driving of R possible. If current flows through element R, it heats up and the resistance is lowered. Then the current increases. This brings about voltage fluctuations across r and the output of the Op Amp (105), which is the input of the comparator 107. Another input of the reference voltage that corresponds to the comparator is the desired print density, which is being sent from the controller. Both inputs are compared, one at a time.

While the input of Op Amp 105 falls short of the desired voltage, the transistor will continue to drive until the correct level is attained. But when it reaches the correct level or rises above it, the FF will reset and heating will stop.

FIGURE 3. Temperature Control Principle

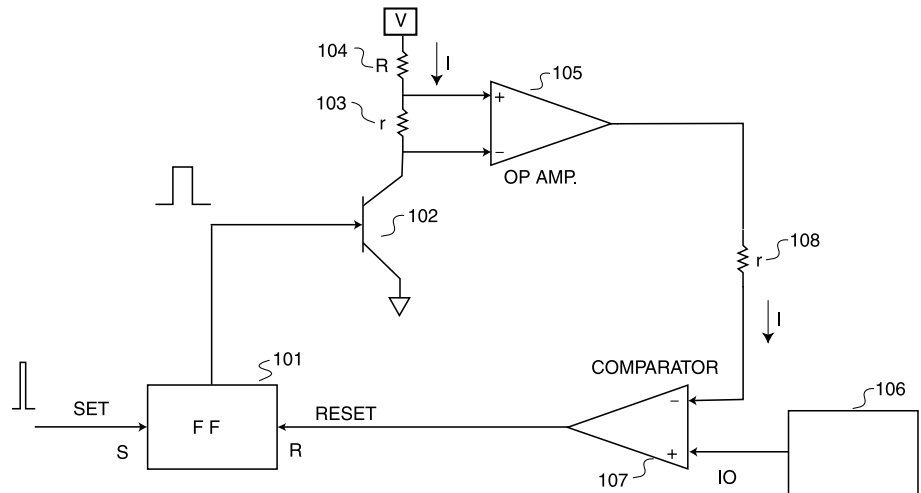

CIRCUIT STRUCTURE

Figure 4 shows the a circuit schematic of the printhead control circuit. At the left side of the schematic diagram is the printhead's internal circuit. The printhead consists of 18 circuits of 64 dots. Dot density is controlled by varying voltage levels applied to the thermal resistor heating elements. By strobbing the circuits, the voltage across all elements can be measured and the voltage is a correlation of the temperature. (There are now three related patents pending on this process.) The right side of the schematic diagram represents the 35K-gate ASIC. Included in the ASIC is the controller used to determine variation of resistance which ensures consistency of print data.

FIGURE 4. Head Control Circuit Structure

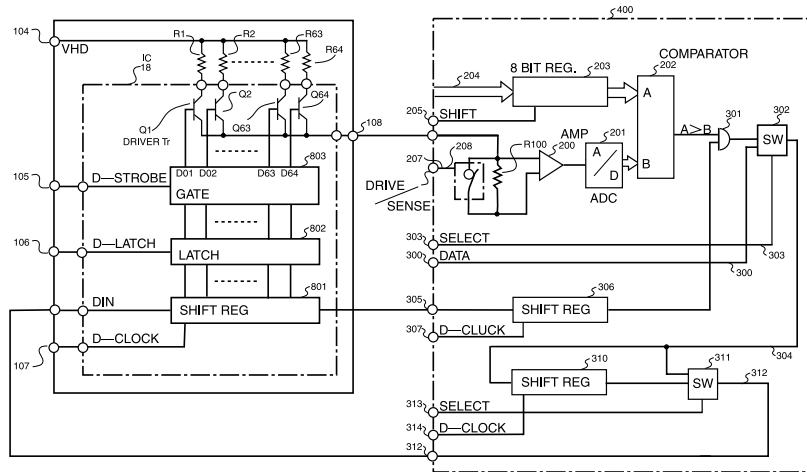

FIXED TEMPERATURE

Figure 5 is a photo showing the result of measuring the voltage (temperature) fluctuations of elements across the terminals. During repeated rises in temperature, a common target temperature is reached. The valleys of the waveform are rising due to retained heat, but the peaks are fixed for each print cycle.

FIGURE 5. Voltage Fluctuation

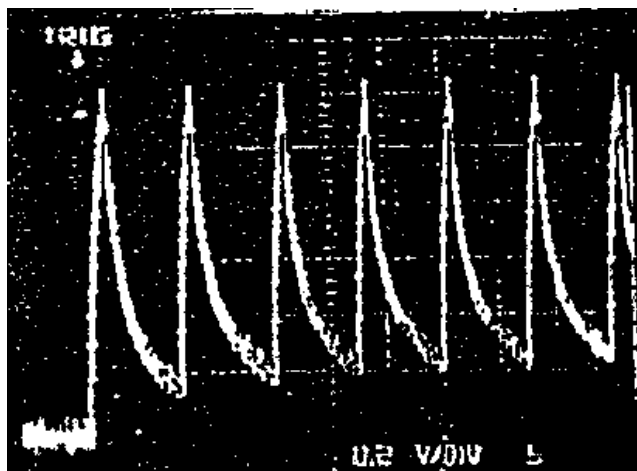

IMPROVED ENERGY CONTROL

The discussion above explains in simple terms how the control circuit sets the heating element to a target temperature. But in more exact terms, the print density on thermal paper is actually dictated by the applied heat energy. With Intelligent Thermal Technology, further improvements have been made by incorporating a method to control applied energy, rather than temperature. Figure 6 shows the improved heat control (energy control method) of the Intelligent Thermal Technology printhead. Even though the temperature is cut off at the constant level (t_0), the energy applied at the base temperature is different (t_b and t_a).

FIGURE 6.

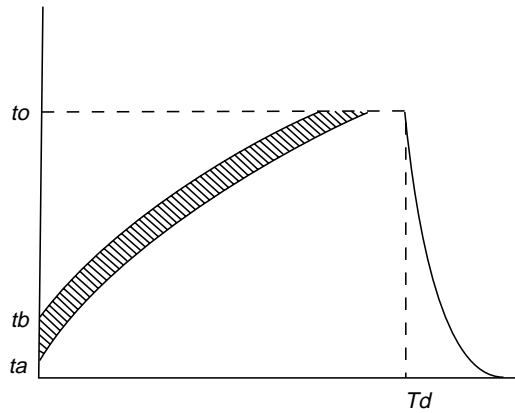
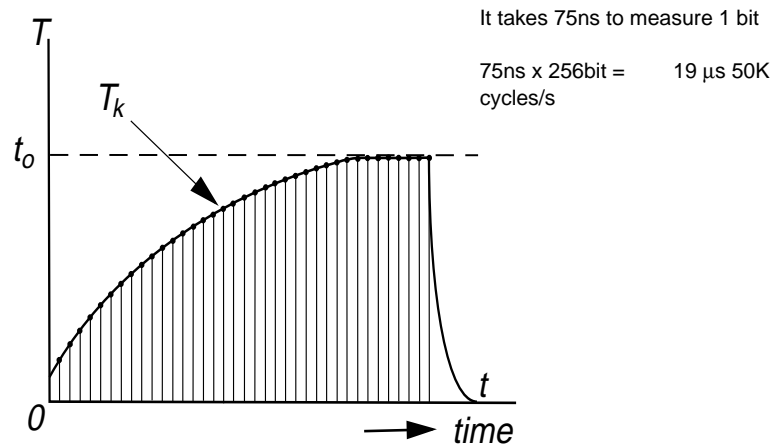

Figure 7 mathematically shows how the temperature measured at each cycle is added by the accumulator to calculate the applied energy density $d=k \sum T_k$

FIGURE 7.



IMPROVED HEAT CONTROL Figure 8 illustrates how the print density on paper is determined by the energy applied by Intelligent Thermal Technology's heating element.

FIGURE 8.

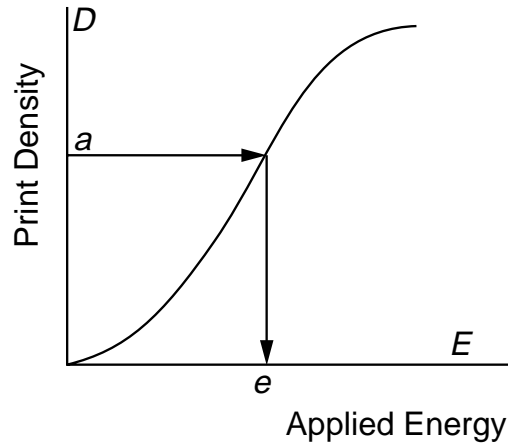

IN CONCLUSION

In conclusion, the evidence presented in this paper clearly shows how the Intelligent Thermal Technology thermal printhead system is an improved way to accomplish superior printing. Temperature is accurately controlled so that energy is conserved resulting in higher quality printing at lower operational cost. Faster more consistent print speeds are also achieved. And because this new printhead system is not subjected to frequent periods of high heat, its elements will last longer. This reliable technology can optimize direct thermal, thermal transfer, or dye-sublimation printing. It can be used with a variety of media including re-writable thermal media, hologram (on-demand) thermal copy media, and color thermal media such as Fuji's Thermal Autochrome. For more information on how Intelligent Thermal Technology can revolutionize your product contact us at